

## PART III: BOOTH CONSTRUCTION FORMS

### 第三部分：攤位裝修表格

FORM 表格	DESCRIPTION 表格名稱	SUBMISSION 表格遞交	DEADLINE 遞交期限	RETURN TO 交回
2.1	Raw Space Exhibitors' Declaration 展覽空地參展商申報	Compulsory for Raw Space Exhibitors 空地參展商必須交回	10.10.2014	HKJMA
2.2	LED Light / Strong White Light Packages LED燈或白光燈攤位設計	Compulsory for Standard Booth Exhibitors 標準攤位參展商必須交回	10.10.2014	AKI Productions Ltd.
2.3	Selection of Strong White Light Booth Package 選擇白光燈攤位設計	Optional for Standard Booth Exhibitors 標準攤位參展商必須交回	10.10.2014	AKI Productions Ltd.
2.4	Booth Fascia Board & Booth ID Sign 招牌板及展位ID指示牌	Compulsory for Standard Booth Exhibitors 標準攤位參展商必須交回	10.10.2014	AKI Productions Ltd.
Package 1-6 -- LED Light LED燈攤位設計 Package A-F -- Strong White Light 白光燈攤位設計 Specification of Furniture 傢俬設施之規格				
2.5	Rental of Additional Furniture 租用額外傢俬設施	Optional (Shell Scheme Only) 隨意交回 (只供標準攤位選用)	10.10.2014	AKI Productions Ltd.
2.6A	Rental of Additional Lights and Electricity 租用額外電燈及電力設施	Optional (Shell Scheme Only) 隨意交回 (只供標準攤位選用)	10.10.2014	AKI Productions Ltd.
2.6B	Rental of Additional Electricity 租用額外電力設施	Optional (Raw Space Booth Only) 隨意交回 (只供空地攤位選用)	10.10.2014	AKI Productions Ltd.
3A	Telephone, Facsimile & Data Line Service Rental 租用電話、傳真及數據線路	Optional 隨意交回	24.10.2014	HKCEC

## BANK DETAILS FOR ORDER OF FACILITIES (FURNITURE & ELECTRICITY)

### 攤位設施之租用及電力接駁的付款詳情

For any booth construction inquiry, please contact the official contractor:

有關攤位搭建之查詢，請聯絡大會承建商：

#### Contact Information

### AKI Productions Ltd.

Address 地址 Flat B, 17/F, Tung Lee Commercial Building, 91- 97 Jervois Street, Sheung Wan, Hong Kong  
香港上環蘇杭街91-97號東利商業大廈17樓B室

Tel 電話 (852) 2697 1221

Fax 傳真 (852) 2603 0814

Email 電郵 show@akipro.com.hk

#### Payment Details

- All orders must be submitted with full payment. Payment can be made by cheque or bank transfer.  
所有額外設施以及攤位改動申請必須連同所需款項交回，所需款項可以支票或銀行轉帳支付。
- All bank charges will be borne by the payer.  
所有銀行手續費需由付款人支付。

**Please note!!**

#### 1. Payment by cheque 以支票形式支付

Cheque should be made payable to “AKI Productions Ltd.” and send to the above address.  
支票抬頭為“AKI Productions Ltd.”，並郵寄致以上地址。

#### 2. Payment by bank transfer 以銀行轉帳支付

Name of Bank 銀行名稱: HSBC Hong Kong 香港上海滙豐銀行

Address of Bank 銀行地址: 1 Queen's Road Central, HK  
香港中環皇后大道中1號

Account Name 帳戶名稱: AKI Productions Ltd.

Account no 帳號: 652-323338-838

Bank Swift code : HSBCHKHCHK

**Form 2.1 Raw Space Exhibitor Declaration**

**表格2.1 展覽空地參展商申報**

Return to 交回: Tris Ng (HKJMA)

Tel 電話: +852 2122-5078 Fax 傳真: +852 2362-3647 Email 電郵: trisng@jewelry.org.hk

**Deadline : October 10, 2014 | 截止日期 : 2014年10月10日**

Exhibitors using non-official contractors to decorate their booth MUST submit the technical drawings with clear dimensions of your booth design for approval. Once the booth design is approved, no alternation may be made without the prior written consent of the Organizer. 聘用私人承建商裝修攤位者，必須將所有攤位設計圖(須列明高度)送交主辦機構審核，一經審核，若非得到主辦機構書面許可，參展商不得擅自更改。

**PART I Exhibitors' Information 參展商資料**

Exhibiting Company Name 參展公司名稱: \_\_\_\_\_

Booth Number 攤位號碼: \_\_\_\_\_

Person in charge on site 現場負責人: \_\_\_\_\_ Position 職位: \_\_\_\_\_

Tel 電話: \_\_\_\_\_ Fax 傳真: \_\_\_\_\_ Mobile 手機: \_\_\_\_\_

Email 電郵: \_\_\_\_\_

**PART II Contractor Information 承建商資料**

Name of Contractor 承建商: \_\_\_\_\_

Person in charge on site 現場負責人: \_\_\_\_\_

Position 職位: \_\_\_\_\_

Tel 電話: \_\_\_\_\_ Fax 傳真: \_\_\_\_\_ Mobile 手機: \_\_\_\_\_

Email 電郵: \_\_\_\_\_

**PART III Electrical Contractor (Pursuant to Electricity 《Wiring》 Regulations of Electricity Ordinance)**

**電力裝置承建商 (根據香港電力條例的電力《電線接駁》規定)**

Name of Contractor 承建商: \_\_\_\_\_

Registration No. 電力註冊編號: \_\_\_\_\_

Person in charge on site 現場負責人: \_\_\_\_\_

Position 職位: \_\_\_\_\_

Tel 電話: \_\_\_\_\_ Fax 傳真: \_\_\_\_\_ Mobile 手機: \_\_\_\_\_

Email 電郵: \_\_\_\_\_

**PART IV Other Requirements if applicable (For information only) 其他需要(只供參考用)**

Contractor Badge Quantity: 承建商工作証數量:	Vehicle Pass Quantity: 車輛通行証數量:
---	------------------------------------

Compulsory for Raw Space Exhibitors  
空地參展商必須交回

Company Chop & Authorized Signature 公司蓋章及簽署

Date 日期

**Form 2.2 LED Light Packages (white light) / Strong White Light Packages**  
**表格2.2 LED燈(白光) / 白光燈攤位設計**

Return to 交回: AKI Productions Ltd.  
 Tel 電話: +852 2697-1221 Fax 傳真: +852 2603-0814 Email 電郵: show@akipro.com.hk  
**Deadline : October 10, 2014 | 截止日期 : 2014年10月10日**

Hong Kong Jewelry Manufacturers' Association provides different LED light and strong white light packages to all standard booth exhibitors. Facilities of LED light package (Refer to P. 43-48 of service manual) are included in the participation fee. Surcharge is applied to Strong White Light package, please refer to P. 49-54. 香港珠寶製造業廠商會為標準攤位之參展商提供多種LED燈或白光燈攤位設計。LED燈攤位之攤位設施已包括在參展費內。各款LED燈攤位的設計內容，請參考P.43-48。白光燈攤位需額外收費，價錢請參考P.49-54。

We require \* LED Light Package (white light) / Strong White Light Package No.: \_\_\_\_\_  
 \*with / without amendment (\*Delete where appropriate) as in the following.  
 本公司選擇 \* LED燈(白光) / 白光燈攤位設計編號為: \_\_\_\_\_  
 \*需要 / 不需要 (\*請刪除不適用者) 新佈置攤位設計如下:

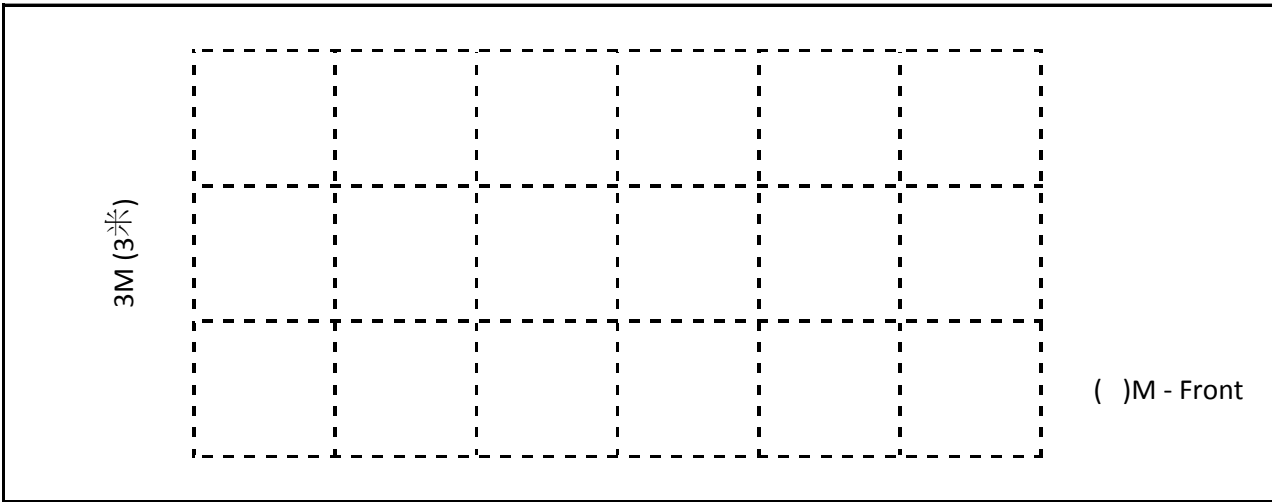

**\*\* All relocation of showcases and lighting fixtures requested before the deadline, October 10, 2014 are free of charge. Relocation of standard items received after October 10, 2014 will be regarded as late order and is subject to a handling charge of HK\$ 300 per application. After October 24, 2014, the handling charge will be HK\$ 500 per application if the order is accepted.**

於2014年10月10日前申請更改任何標準攤位設施，包括取消 / 重新佈置陳列飾櫃或照明設備，一律免費。於截止日期（2014年10月10日）後申請更改任何標準攤位設施，參展商須繳付處理附加費每次HK\$300。於2014年10月24日後，申請若被接納則處理附加費每次HK\$500。

Company Name 公司名稱: \_\_\_\_\_  
 Booth Number 攤位號碼: \_\_\_\_\_ Contact Person 負責人: \_\_\_\_\_  
 Tel 電話: \_\_\_\_\_ Fax 傳真: \_\_\_\_\_ Email 電郵: \_\_\_\_\_

Company Chop & Authorized Signature 公司蓋章及簽署 \_\_\_\_\_ Date 日期 \_\_\_\_\_

**Form 2.3 Selection of Strong White Light Booth Package**

**表格2.3 選擇白光燈攤位設計**

Return to 交回: AKI Productions Ltd.

Tel 電話: +852 2697-1221 Fax 傳真: +852 2603-0814 Email 電郵: show@akipro.com.hk

**Deadline : October 10, 2014 | 截止日期 : 2014年10月10日**

For exhibitors who select strong white light package only 只供選擇白光燈之參展商填寫  
(Not applicable for exhibitors in Machinery, Packaging and Servicing Zone 不適用於珠寶儀器、包裝及服務館)  
Apart from the LED Light Packages, 6 Strong White Light Packages (70W or 250W) are available for rental. In the Strong White Light Booth Packages, 1 Strong White Light (70W) will be provided for each showcase instead of 3 LED lights and 1 built-in fluorescent tube as in the LED Light Packages. Please refer to page 49-54 for Strong White Light Packages A-F.

現提供6款白光燈(70W或250W)攤位設計供參展商租用。白光燈攤位設計的陳列飾櫃會以1盞白光燈代替LED燈攤位設計的3盞LED燈及1支內置光管。請參閱P.49-54的白光燈攤位款式(攤位圖A-F)。

**We would like to order the following Strong White Light Package:**

本公司選擇以下之白光燈攤位款式：

	Corner (轉角位)	Surcharge 額外收費	
		Strong White Light 70W 70W 白光燈	Strong White Light 250W 250W 白光燈
9 m <sup>2</sup> standard booth (9平方米標準攤位)	0	HK\$1,220 <input type="checkbox"/>	HK\$2,040 <input type="checkbox"/>
9 m <sup>2</sup> corner booth (9平方米轉角攤位)	1	HK\$2,440 <input type="checkbox"/>	HK\$4,080 <input type="checkbox"/>
18 m <sup>2</sup> standard booth (18平方米標準攤位)	0	HK\$2,440 <input type="checkbox"/>	HK\$4,080 <input type="checkbox"/>
18 m <sup>2</sup> corner booth (18平方米轉角攤位)	1	HK\$3,660 <input type="checkbox"/>	HK\$6,120 <input type="checkbox"/>
27 m <sup>2</sup> corner booth (27平方米轉角攤位)	1	HK\$4,880 <input type="checkbox"/>	HK\$8,160 <input type="checkbox"/>
36 m <sup>2</sup> corner booth (36平方米轉角攤位)	1	HK\$7,320 <input type="checkbox"/>	HK\$12,240 <input type="checkbox"/>

Terms & Conditions 註明:

1. Should there be any surcharge, payment should be prepared by cheque or bank transfer. Order without payment will not be entertained. 如有額外費用，請準備所需款項並以支票或銀行轉帳支付。未繳款之訂單，恕不受理。
2. If exhibitors do not return this form to AKI before the deadline, the Organizer will choose any type of LED Light Package on behalf of for your company. 若某參展商於截止日期前尚未遞交此表，主辦機構有權為該參展商挑選其中一款標準LED燈攤位組合，屆時該參展商不得異議。
3. AKI Productions Ltd. reserves the right to accept late order (after October 10, 2014). Change of package (LED Light Package or Strong White Light) received after October 10, 2014 will be regarded as an amended order and is subject to a handling charge of HK\$300 per application. After October 24, 2014, no amendment will be accepted. 若於截止日期後遞交此申請表(2014年10月10日以後)，AKI Productions Ltd. 保留接受申請之權利。於截止日期(2014年10月10日)後申請更改標準攤位選擇(LED燈攤位設計/白光燈攤位設計)，參展商須繳付處理附加費每次HK\$300。於2014年10月24日後，一切更改申請恕不受理。

**For payment method, please refer to P.38. 有關付款方法，詳情請參閱第38頁。**

Company Name 公司名稱: \_\_\_\_\_  
Booth Number 攤位號碼: \_\_\_\_\_ Contact Person 負責人: \_\_\_\_\_  
Tel 電話: \_\_\_\_\_ Fax 傳真: \_\_\_\_\_ Email 電郵: \_\_\_\_\_

Company Chop & Authorized Signature 公司蓋章及簽署

Date 日期

Optional  
隨意交回

**Form 2.4 Booth Fascia Board & Booth ID Sign**  
**表格2.4 招牌板及展位ID指示牌**

Return to 交回: AKI Productions Ltd.

Tel 電話: +852 2697-1221 Fax 傳真: +852 2603-0814 Email 電郵: show@akipro.com.hk

**Deadline : October 10, 2014 | 截止日期 : 2014年10月10日**

**Booth Fascia Board 展位招牌板**

Your company name on Application Form / Contract will be printed on Fascia Board.  
 展位招牌板將會使用申請表格 / 合約上之公司名稱。

**Booth ID Sign 展位ID指示牌**

- Each 9m<sup>2</sup> standard booth exhibitor is entitled to one (1) complimentary booth ID sign.  
 主辦機構免費提供每9m<sup>2</sup> 標準攤位參展商一個展位ID 指示牌。
- The size of the sign is 300mm (W) x 155mm (H).  
 指示牌面積為 300mm (W) x 155mm (H)。
- Booth ID signs are placed on the top of every open side of the booth.  
 指示牌置於每個展位的開口處。
- Fill-in in English. Two (2) lines of maximum 10 character each.  
 請用英文填寫，公司名稱字數每行不多於10個英文字母（共兩行）。

**Company Name (Please print or type in English) 公司名稱 (請以英文正楷填寫)**

Company Name 公司名稱: \_\_\_\_\_  
 Booth Number 攤位號碼: \_\_\_\_\_ Contact Person 負責人: \_\_\_\_\_  
 Tel 電話: \_\_\_\_\_ Fax 傳真: \_\_\_\_\_ Email 電郵: \_\_\_\_\_

\_\_\_\_\_  
 Company Chop & Authorized Signature 公司蓋章及簽署

\_\_\_\_\_  
 Date 日期

Compulsory for Standard Booth Exhibitors  
 標準攤位之參展商必須交回

**Hong Kong International Jewelry Manufacturers' Show 2014**

**LED Light Package 1**

Standard Booth (3m x 3m)

Plan

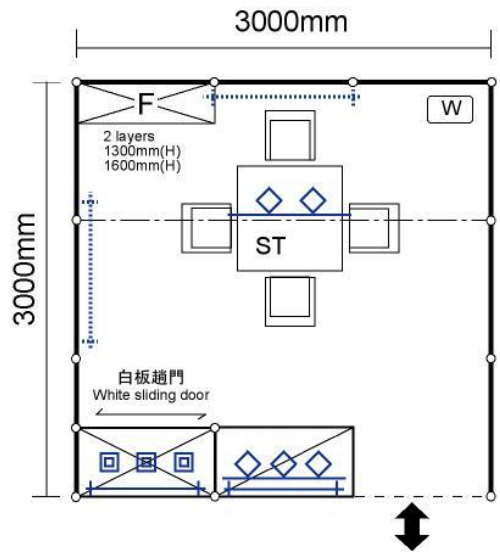

Perspective

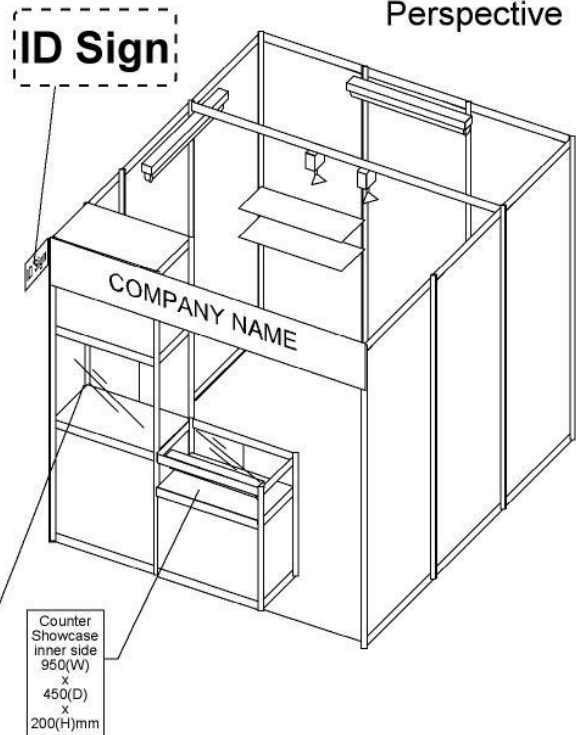

Tall Showcase inner side  
 950(W)  
 x  
 450(D)  
 x  
 695(H)mm

Counter Showcase inner side  
 950(W)  
 x  
 450(D)  
 x  
 200(H)mm

CONTENTS	QTY
矮身陳列飾櫃 1米路軌連3盞路軌LED燈(5W)(白光) 及1支內置光管(白光) Counter Showcase with 3 LED Tracklights (5W)(White Light) at 1m Light Track on top & 1 built-in fluorescent tube (White Light)	1
高身陳列飾櫃 連3盞內置LED燈(5W)(白光)及1支內置光管(白光) Tall Showcase with 3 built-in LED Downlights (5W)(White Light) & 1 built-in fluorescent tube (White Light)	1
平放式陳列架 Flat shelves [300mm(D) X 1000mm(L)]	2
方檯 Table	1
黑皮椅 Black Leather Chair	4
廢物箱 Waste basket	1
1米路軌連2盞路軌LED燈(5W)(白光) 2 LED Tracklights (5W) (White Light) at 1m Light Track on top	1
光管(1200mmL)(白光) Fluorescent tube (1200mmL)(White Light)	2

攤位組合的所有飾櫃可自由選擇高身陳列飾櫃或矮身陳列飾櫃  
 All showcase within the Package can interchange between Tall showcase or Counter showcase.

# Hong Kong International Jewelry Manufacturers' Show 2014

## LED Light Package 2

Corner Booth  
(3m x 3m)

Plan

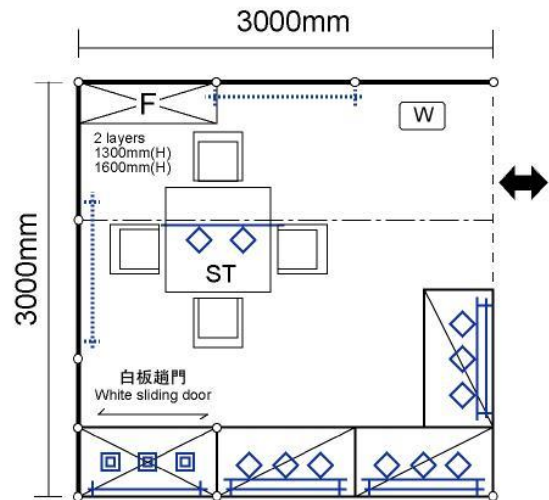

Perspective

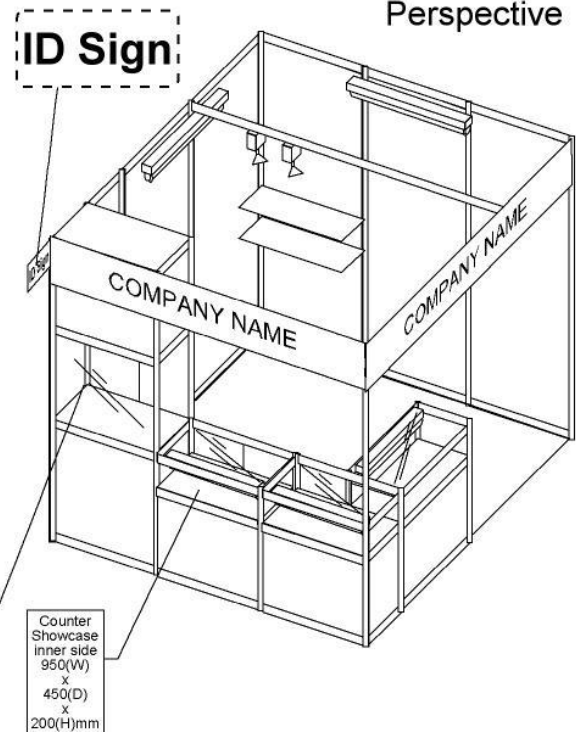

Tall Showcase  
inner side  
950(W)  
x  
450(D)  
x  
695(H)mm

Counter Showcase  
inner side  
950(W)  
x  
450(D)  
x  
200(H)mm

CONTENTS	QTY
矮身陳列飾櫃 1米路軌連3盞路軌LED燈(5W)(白光) 及1支內置光管(白光) Counter Showcase with 3 LED Tracklights (5W)(White Light) at 1m Light Track on top & 1 built-in fluorescent tube (White Light)	3
高身陳列飾櫃 連3盞內置LED燈(5W)(白光)及1支內置光管(白光) Tall Showcase with 3 built-in LED Downlights (5W)(White Light) & 1 built-in fluorescent tube (White Light)	1
平放式陳列架 Flat shelves [300mm(D) X 1000mm(L)]	2
方檯 Table	1
黑皮椅 Black Leather Chair	4
廢物箱 Waste basket	1
1米路軌連2盞路軌LED燈(5W)(白光) 2 LED Tracklights (5W) (White Light) at 1m Light Track on top	1
光管(1200mmL)(白光) Fluorescent tube (1200mmL)(White Light)	2

攤位組合的所有飾櫃可自由選擇高身陳列飾櫃或矮身陳列飾櫃  
All showcase within the Package can interchange between Tall showcase or Counter showcase.



**Hong Kong International Jewelry Manufacturers' Show 2014**

**LED Light Package 3**

Standard Booth (6m x 3m)

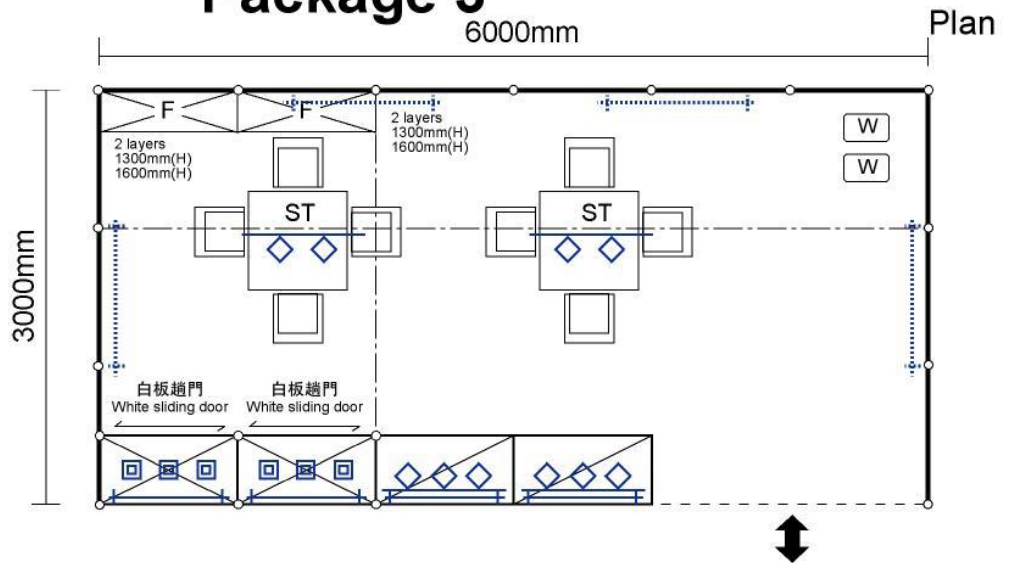

CONTENTS	QTY
矮身陳列飾櫃 1米路軌連3盞路軌LED燈(5W)(白光) 及1支內置光管(白光) Counter Showcase with 3 LED Tracklights (5W)(White Light) at 1m Light Track on top & 1 built-in fluorescent tube (White Light)	2
高身陳列飾櫃 連3盞內置LED燈(5W)(白光)及1支內置光管(白光) Tall Showcase with 3 built-in LED Downlights (5W)(White Light) & 1 built-in fluorescent tube (White Light)	2
平放式陳列架 Flat shelves [300mm(D) X 1000mm(L)]	4
方檯 Table	2
黑皮椅 Black Leather Chair	8
廢物箱 Waste basket	2
1米路軌連2盞路軌LED燈(5W)(白光) 2 LED Tracklights (5W) (White Light) at 1m Light Track on top	2
光管(1200mmL)(白光) Fluorescent tube (1200mmL)(White Light)	4

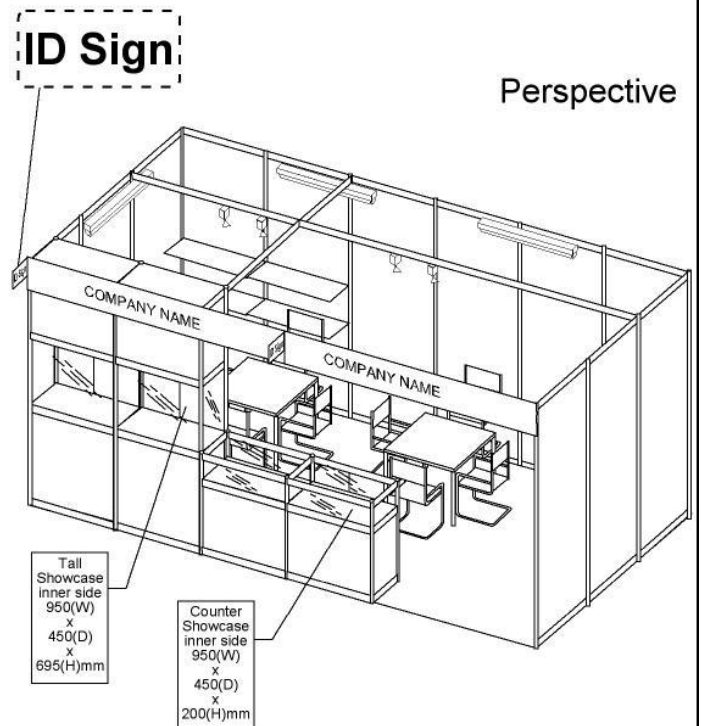

**攤位組合的所有飾櫃可自由選擇高身陳列飾櫃或矮身陳列飾櫃**  
 All showcase within the Package can interchange between Tall showcase or Counter showcase.

**Hong Kong International Jewelry Manufacturers' Show 2014**

**LED Light Package 4**

**Corner Booth (6m x 3m)**

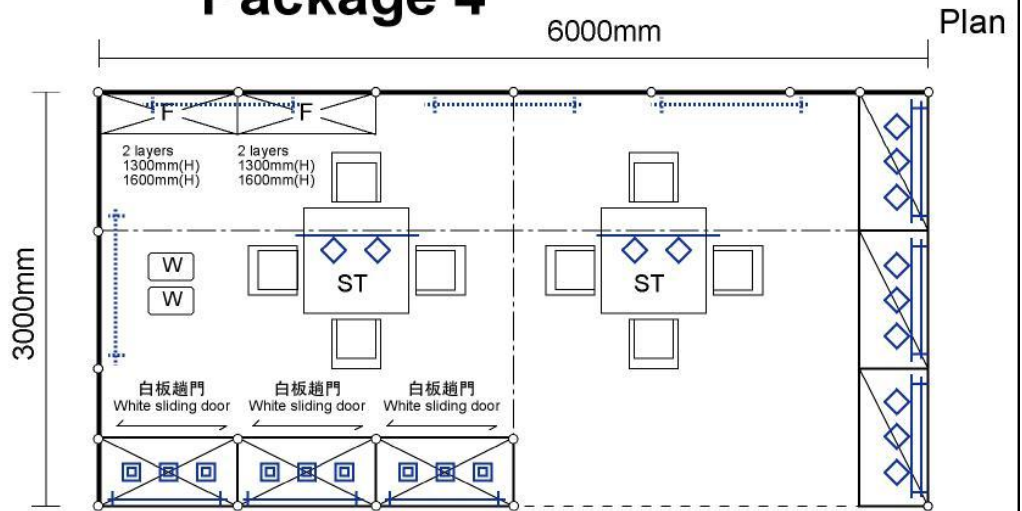

CONTENTS	QTY
矮身陳列飾櫃 1米路軌連3盞路軌LED燈(5W)(白光) 及1支內置光管(白光) Counter Showcase with 3 LED Tracklights (5W)(White Light) at 1m Light Track on top & 1 built-in fluorescent tube (White Light)	3
高身陳列飾櫃 連3盞內置LED燈(5W)(白光)及1支內置光管(白光) Tall Showcase with 3 built-in LED Downlights (5W)(White Light) & 1 built-in fluorescent tube (White Light)	3
平放式陳列架 Flat shelves [300mm(D) X 1000mm(L)]	4
方檯 Table	2
黑皮椅 Black Leather Chair	8
廢物箱 Waste basket	2
1米路軌連2盞路軌LED燈(5W)(白光) 2 LED Tracklights (5W) (White Light) at 1m Light Track on top	2
光管(1200mmL)(白光) Fluorescent tube (1200mmL)(White Light)	4

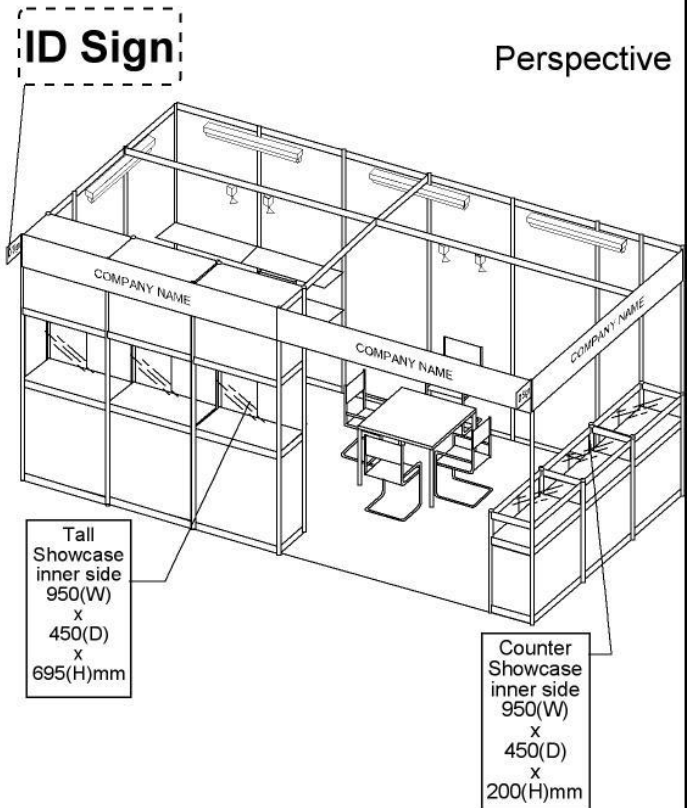

**攤位組合的所有飾櫃可自由選擇高身陳列飾櫃或矮身陳列飾櫃**  
 All showcase within the Package can interchange between Tall showcase or Counter showcase.

**Hong Kong International Jewelry Manufacturers' Show 2014**

**LED Light Package 5**

Corner Booth  
(9m x 3m)

Plan

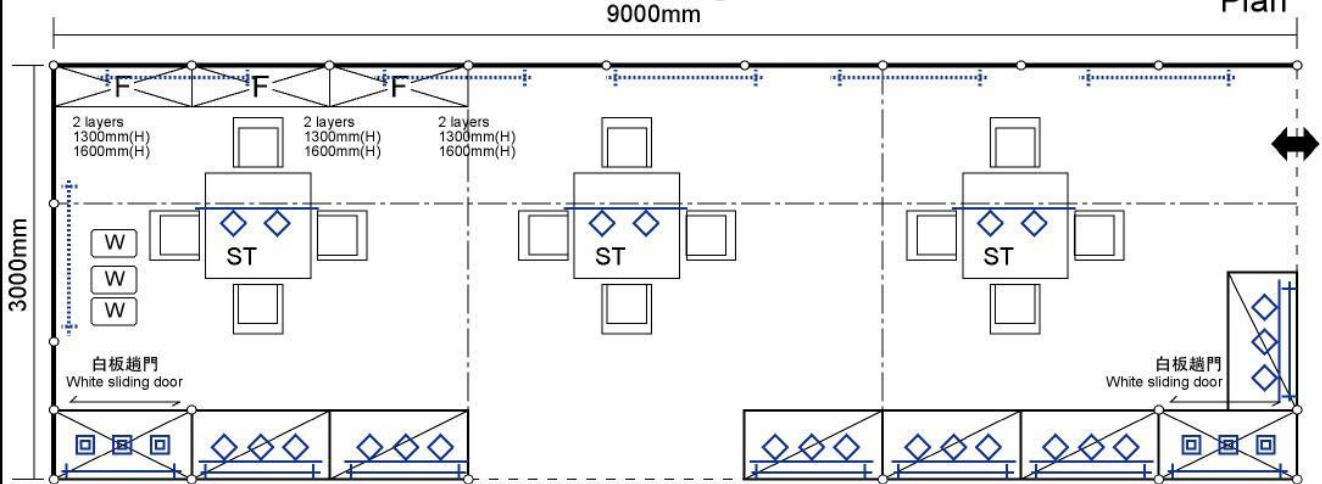

CONTENTS	QTY
矮身陳列飾櫃 1米路軌連3盞路軌LED燈(5W)(白光) 及1支內置光管(白光) Counter Showcase with 3 LED Tracklights (5W)(White Light) at 1m Light Track on top & 1 built-in fluorescent tube (White Light)	6
高身陳列飾櫃 連3盞內置LED燈(5W)(白光)及1支內置光管(白光) Tall Showcase with 3 built-in LED Downlights (5W)(White Light) & 1 built-in fluorescent tube (White Light)	2
平放式陳列架 Flat shelves [300mm(D) X 1000mm(L)]	6
方檯 Table	3
黑皮椅 Black Leather Chair	12
廢物箱 Waste basket	3
1米路軌連2盞路軌LED燈(5W)(白光) 2 LED Tracklights (5W) (White Light) at 1m Light Track on top	3
光管(1200mmL)(白光) Fluorescent tube (1200mmL)(White Light)	6



**ID Sign** Perspective

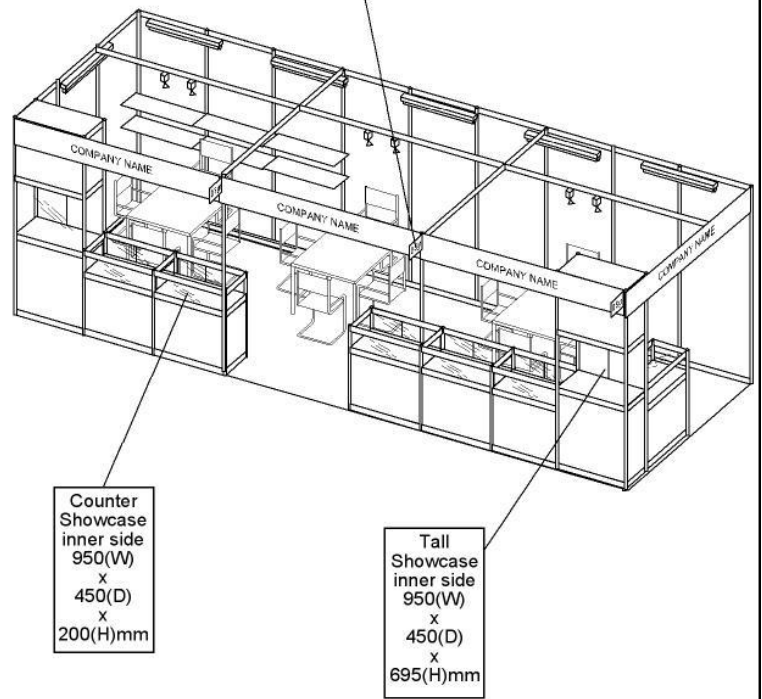

攤位組合的所有飾櫃可自由選擇高身陳列飾櫃或矮身陳列飾櫃  
 All showcase within the Package can interchange between Tall showcase or Counter showcase.

**Hong Kong International Jewelry Manufacturers' Show 2014**

**LED Light Package 6**

Corner Booth  
(6m x 6m)

Plan

CONTENTS	QTY
矮身陳列飾櫃 1米路軌連3盞路軌LED燈(5W)(白光) 及1支內置光管(白光) Counter Showcase with 3 LED Tracklights (5W)(White Light) at 1m Light Track on top & 1 built-in fluorescent tube (White Light)	6
高身陳列飾櫃 連3盞內置LED燈(5W)(白光)及1支內置光管(白光) Tall Showcase with 3 built-in LED Downlights (5W)(White Light) & 1 built-in fluorescent tube (White Light)	6
平放式陳列架 Flat shelves [300mm(D) X 1000mm(L)]	8
方檯 Table	4
黑皮椅 Black Leather Chair	16
廢物箱 Waste basket	4
1米路軌連2盞路軌LED燈(5W)(白光) 2 LED Tracklights (5W) (White Light) at 1m Light Track on top	4
光管(1200mmL)(白光) Fluorescent tube (1200mmL)(White Light)	8

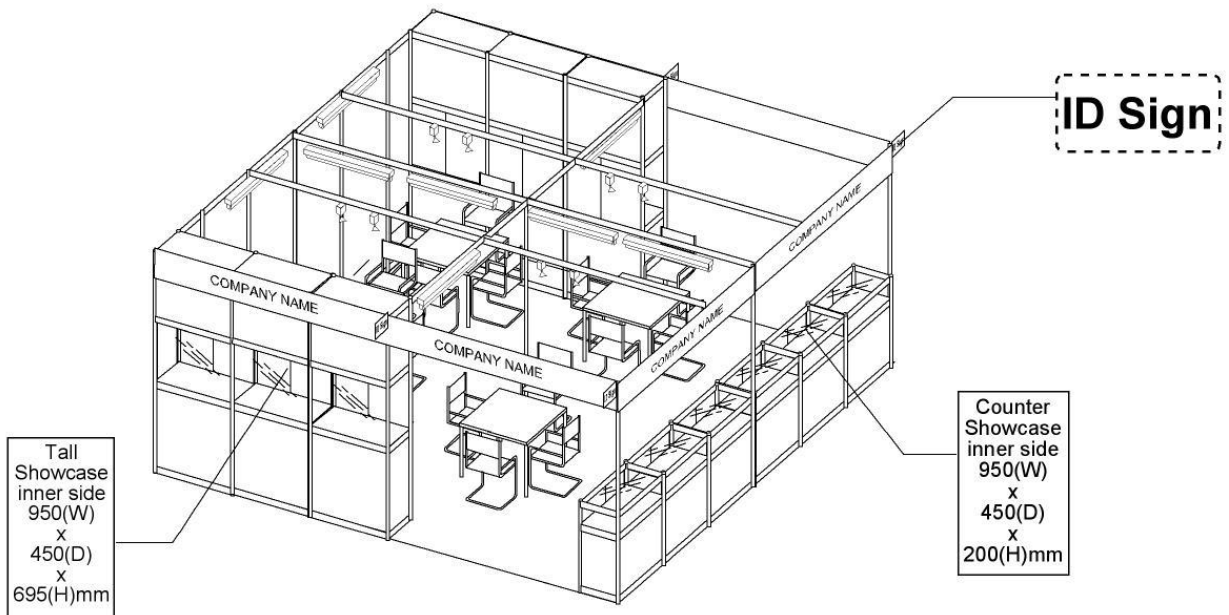
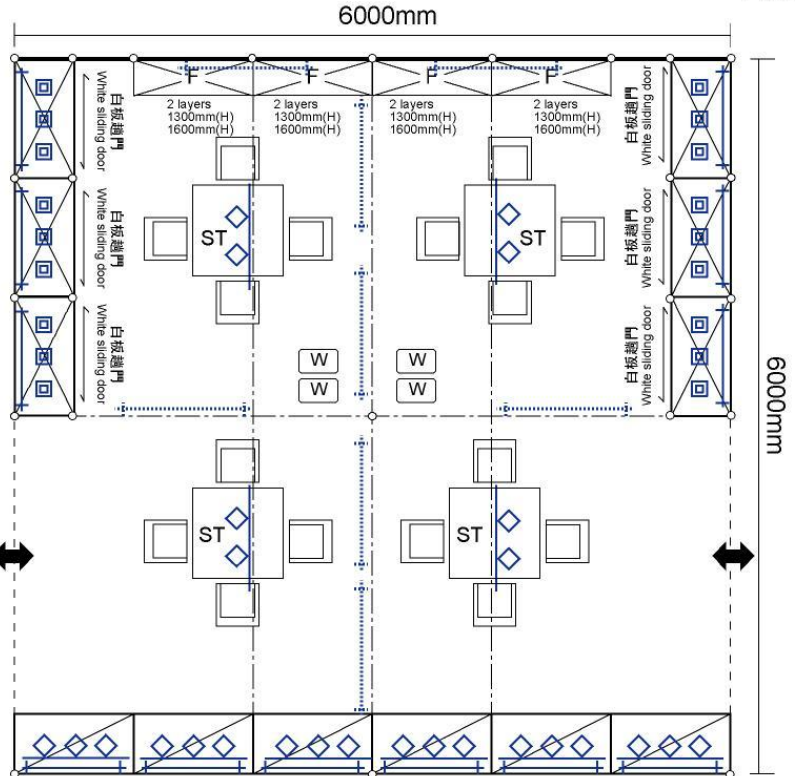

攤位組合的所有飾櫃可自由選擇高身陳列飾櫃或矮身陳列飾櫃  
 All showcase within the Package can interchange between Tall showcase or Counter showcase.

## Hong Kong International Jewelry Manufacturers' Show 2014

**額外收費  
Surcharge**

Strong White Light (70W) --- HK\$ 1,220.00  
 或 / or  
 Strong White Light (250W) -- HK\$ 2,040.00

### Strong White Light Package A

Standard Booth  
(3m x 3m)

CONTENTS	QTY
矮身陳列飾櫃 連1盞白光燈 Counter Showcase with 1 Strong White Light (White Light) on top	1
高身陳列飾櫃 連1盞內置白光燈 Tall Showcase with 1 built-in Strong White light (White Light)	1
平放式陳列架 Flat shelves [300mm(D) X 1000mm(L)]	2
方檯 Table	1
黑皮椅 Black Leather Chair	4
廢物箱 Waste basket	1
1米路軌連2盞路軌LED燈(5W)(白光) 2 LED Tracklights (5W) (White Light) at 1m Light Track on top	1
光管(1200mmL)(白光) Fluorescent tube (1200mmL)(White Light)	2

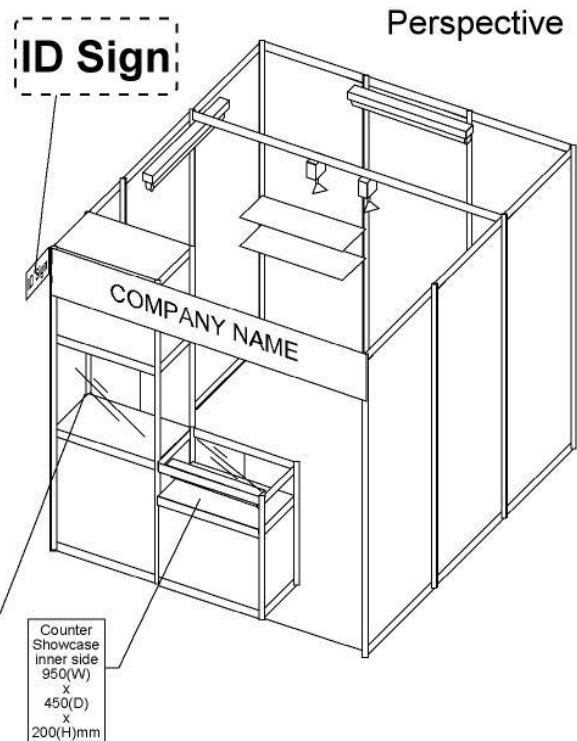
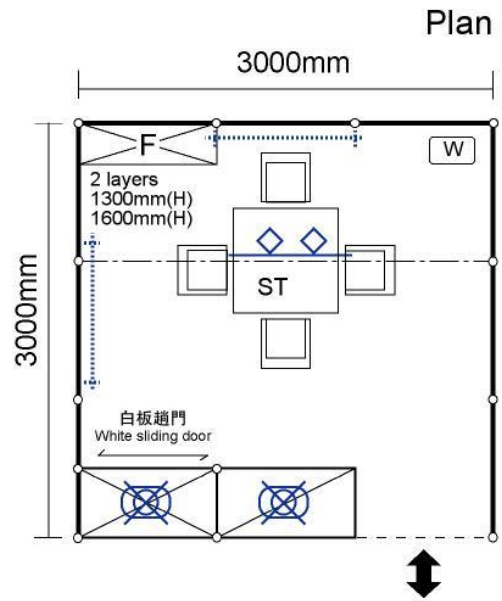

攤位組合的所有飾櫃可自由選擇高身陳列飾櫃或矮身陳列飾櫃  
 All showcase within the Package can interchange between Tall showcase or Counter showcase.

## Hong Kong International Jewelry Manufacturers' Show 2014

### 額外收費 Surcharge

Strong White Light (70W) --- HK\$ 2,440.00  
 或 / or  
 Strong White Light (250W) -- HK\$ 4,080.00

CONTENTS	QTY
矮身陳列飾櫃 連1盞白光燈 Counter Showcase with 1 Strong White Light (White Light) on top	3
高身陳列飾櫃 連1盞內置白光燈 Tall Showcase with 1 built-in Strong White light (White Light)	1
平放式陳列架 Flat shelves [300mm(D) X 1000mm(L)]	2
方檯 Table	1
黑皮椅 Black Leather Chair	4
廢物箱 Waste basket	1
1米路軌連2盞路軌LED燈(5W)(白光) 2 LED Tracklights (5W) (White Light) at 1m Light Track on top	1
光管(1200mmL)(白光) Fluorescent tube (1200mmL)(White Light)	2

### Strong White Light Package B

Corner Booth  
(3m x 3m)

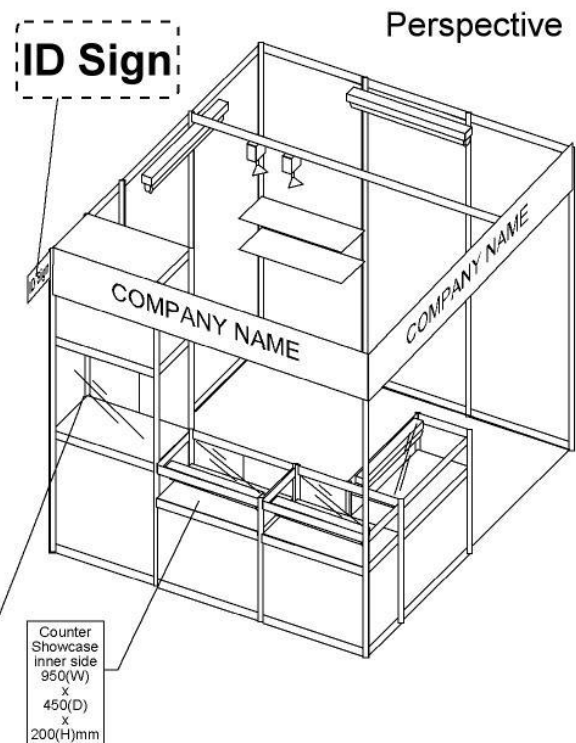
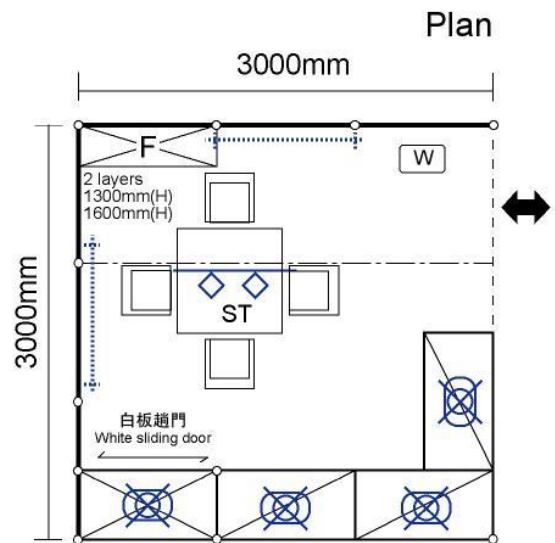

攤位組合的所有飾櫃可自由選擇高身陳列飾櫃或矮身陳列飾櫃  
 All showcase within the Package can interchange between Tall showcase or Counter showcase.

**Hong Kong International Jewelry Manufacturers' Show 2014**

**Strong White Light Package C**

Standard Booth (6m x 3m)

Plan

**額外收費  
 Surcharge**  
 Strong White Light (70W) --- HK\$ 2,440.00  
 或 / or  
 Strong White Light (250W) -- HK\$ 4,080.00

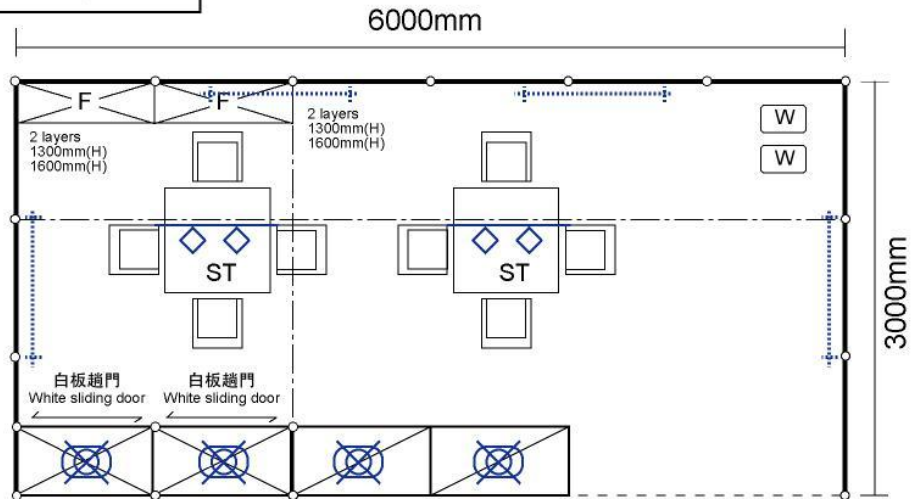

CONTENTS	QTY
矮身陳列飾櫃 連1盞白光燈 Counter Showcase with 1 Strong White Light (White Light) on top	2
高身陳列飾櫃 連1盞內置白光燈 Tall Showcase with 1 built-in Strong White light (White Light)	2
平放式陳列架 Flat shelves [300mm(D) X 1000mm(L)]	4
方檯 Table	2
黑皮椅 Black Leather Chair	8
廢物箱 Waste basket	2
1米路軌連2盞路軌LED燈(5W)(白光) 2 LED Tracklights (5W) (White Light) at 1m Light Track on top	2
光管(1200mmL)(白光) Fluorescent tube (1200mmL)(White Light)	4

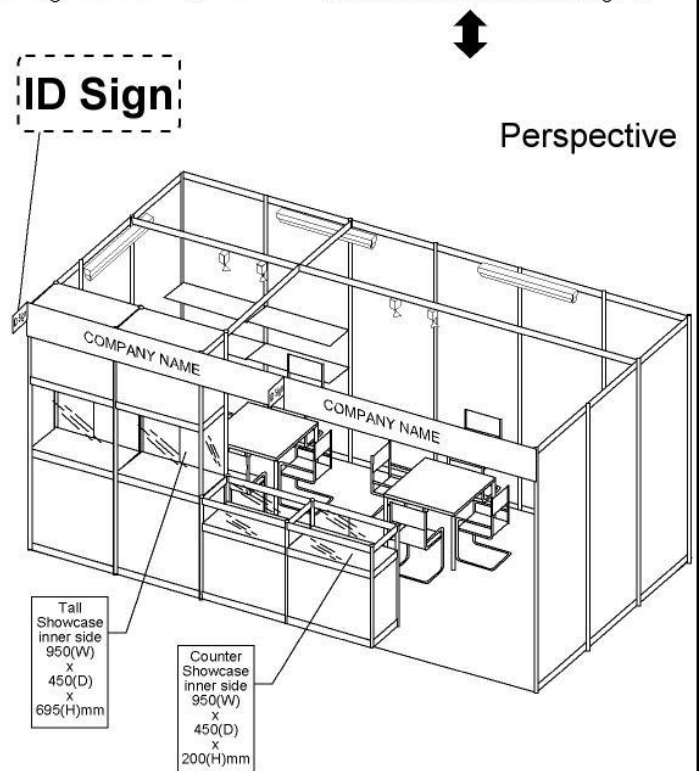

**攤位組合的所有飾櫃可自由選擇高身陳列飾櫃或矮身陳列飾櫃**  
 All showcase within the Package can interchange between Tall showcase or Counter showcase.

**Hong Kong International Jewelry Manufacturers' Show 2014**

**額外收費  
 Surcharge**

Strong White Light (70W) --- HK\$ 3,660.00  
 或 / or  
 Strong White Light (250W) -- HK\$ 6,120.00

**Strong White Light  
 Package D**

**Corner Booth  
 (6m x 3m)**

Plan

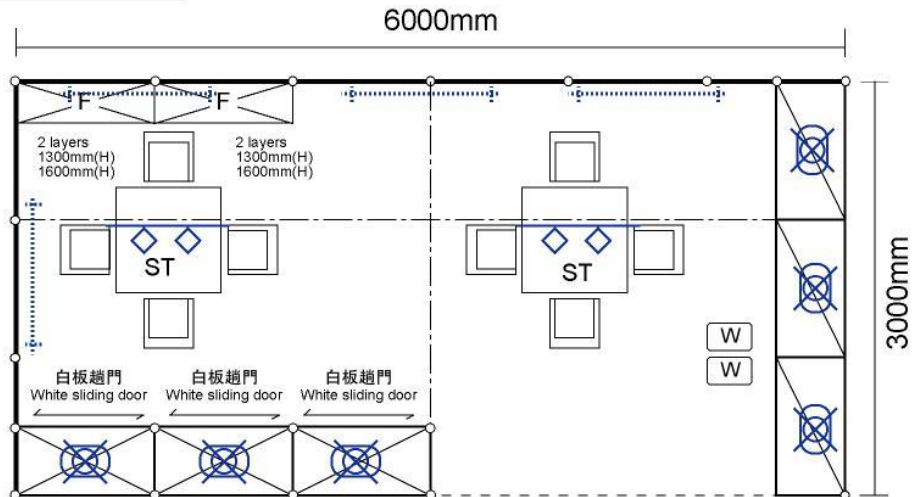

CONTENTS	QTY
矮身陳列飾櫃 連1盞白光燈 Counter Showcase with 1 Strong White Light (White Light) on top	3
高身陳列飾櫃 連1盞內置白光燈 Tall Showcase with 1 built-in Strong White light (White Light)	3
平放式陳列架 Flat shelves [300mm(D) X 1000mm(L)]	4
方檯 Table	2
黑皮椅 Black Leather Chair	8
廢物箱 Waste basket	2
1米路軌連2盞路軌LED燈(5W)(白光) 2 LED Tracklights (5W) (White Light) at 1m Light Track on top	2
光管(1200mmL)(白光) Fluorescent tube (1200mmL)(White Light)	4

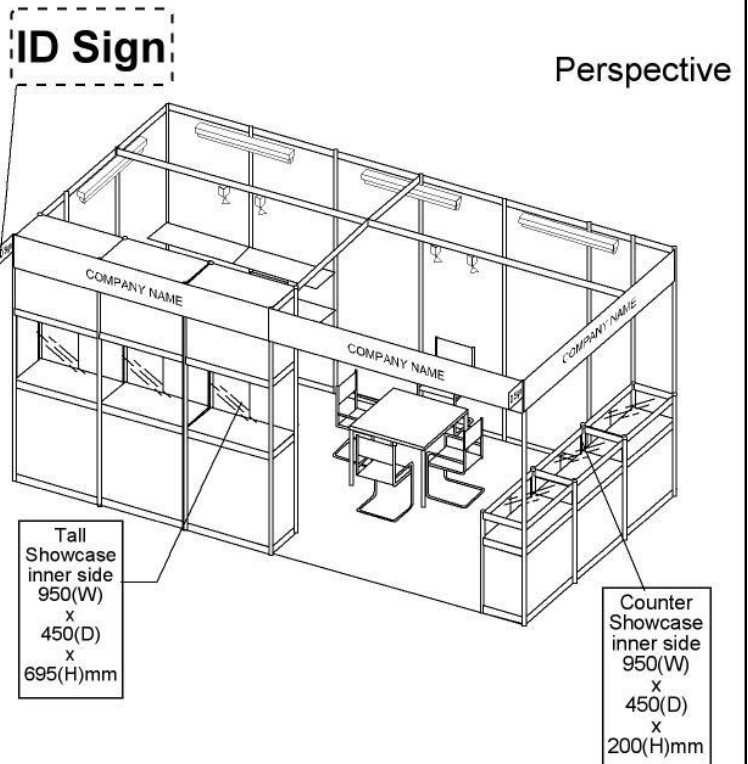

**攤位組合的所有飾櫃可自由選擇高身陳列飾櫃或矮身陳列飾櫃**  
 All showcase within the Package can interchange between Tall showcase or Counter showcase.



**Hong Kong International Jewelry Manufacturers' Show 2014**

**Strong White Light Package E**

Corner Booth  
 (9m x 3m)

**額外收費  
 Surcharge**

Strong White Light (70W) --- HK\$ 4,880.00

或 / or

Strong White Light (250W) -- HK\$ 8,160.00

Plan

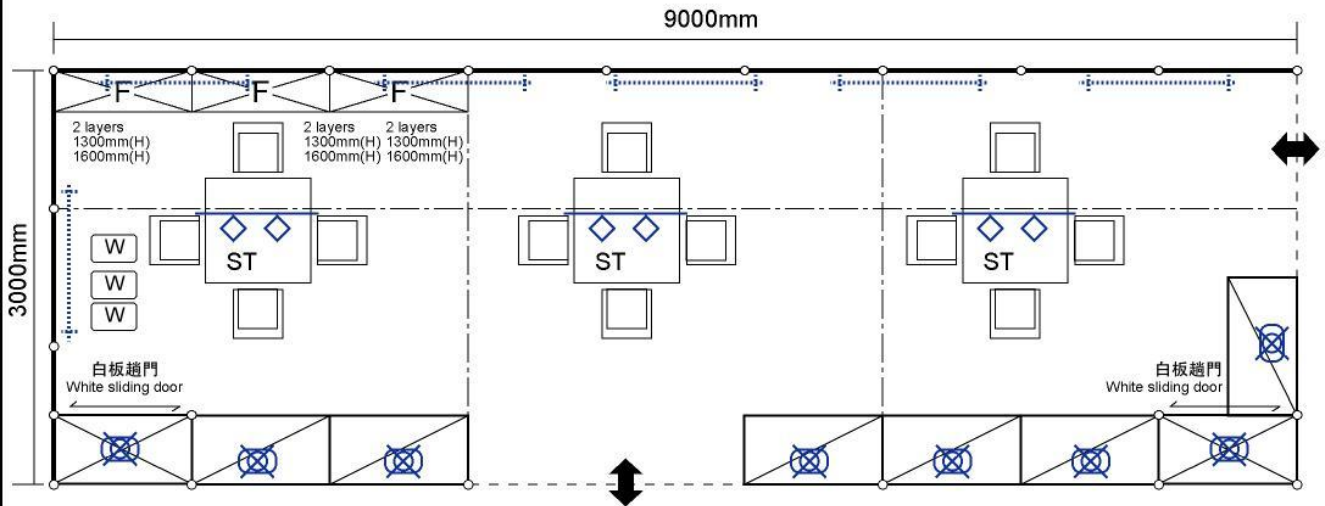

CONTENTS	QTY
矮身陳列飾櫃 連1盞白光燈 Counter Showcase with 1 Strong White Light (White Light) on top	6
高身陳列飾櫃 連1盞內置白光燈 Tall Showcase with 1 built-in Strong White light (White Light)	2
平放式陳列架 Flat shelves [300mm(D) X 1000mm(L)]	6
方檯 Table	3
黑皮椅 Black Leather Chair	12
廢物箱 Waste basket	3
1米路軌連2盞路軌LED燈(5W)(白光) 2 LED Tracklights (5W) (White Light) at 1m Light Track on top	3
光管(1200mmL)(白光) Fluorescent tube (1200mmL)(White Light)	6

**ID Sign**

Perspective

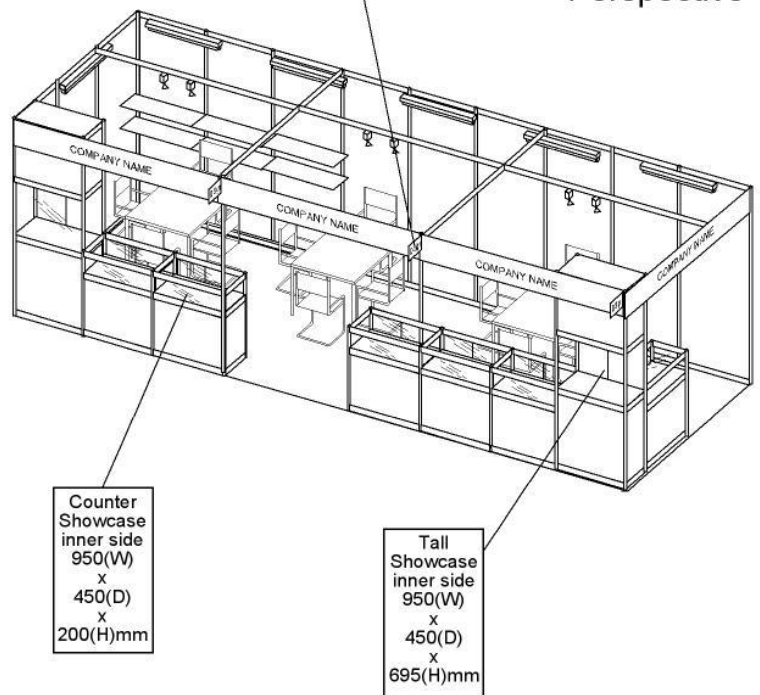

**攤位組合的所有飾櫃可自由選擇高身陳列飾櫃或矮身陳列飾櫃**  
 All showcase within the Package can interchange between Tall showcase or Counter showcase.

**Hong Kong International Jewelry Manufacturers' Show 2014**

**額外收費**  
**Surcharge**  
 Strong White Light (70W) --- HK\$ 7,320.00  
 或 / or  
 Strong White Light (250W) -- HK\$ 12,240.00

CONTENTS	QTY
矮身陳列飾櫃 連1盞白光燈 Counter Showcase with 1 Strong White Light (White Light) on top	6
高身陳列飾櫃 連1盞內置白光燈 Tall Showcase with 1 built-in Strong White light (White Light)	6
平放式陳列架 Flat shelves [300mm(D) X 1000mm(L)]	8
方檯 Table	4
黑皮椅 Black Leather Chair	16
廢物箱 Waste basket	4
1米路軌連2盞路軌LED燈(5W)(白光) 2 LED Tracklights (5W) (White Light) at 1m Light Track on top	4
光管(1200mmL)(白光) Fluorescent tube (1200mmL)(White Light)	8

**Strong White Light Package F**

**Corner Booth (6m x 6m)**

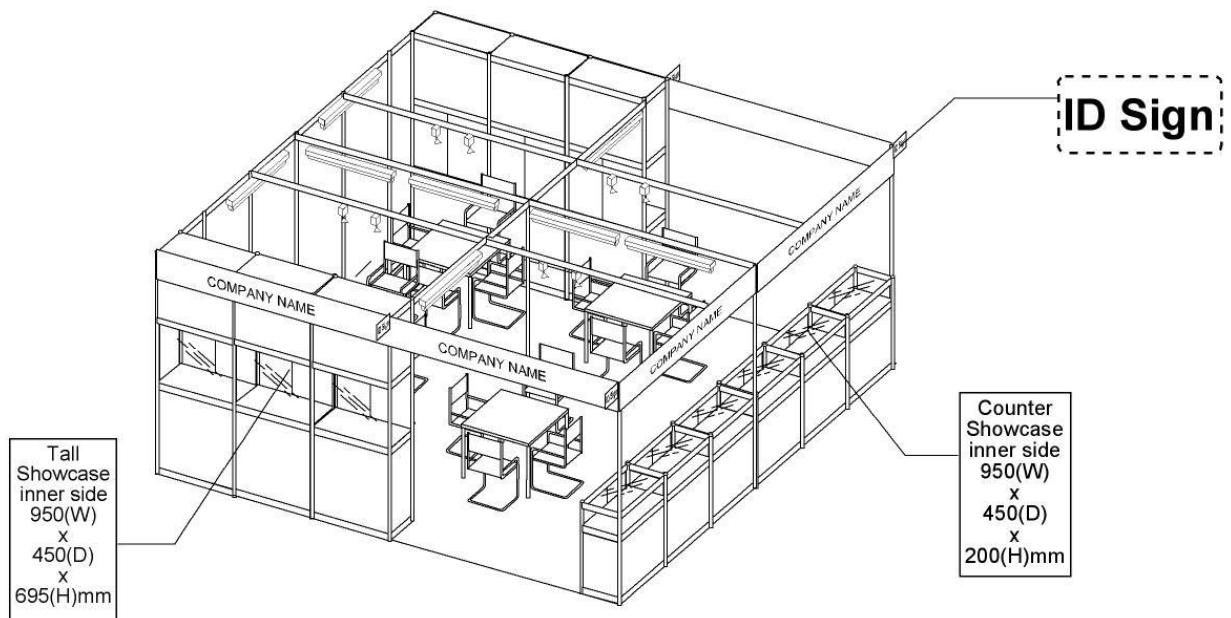
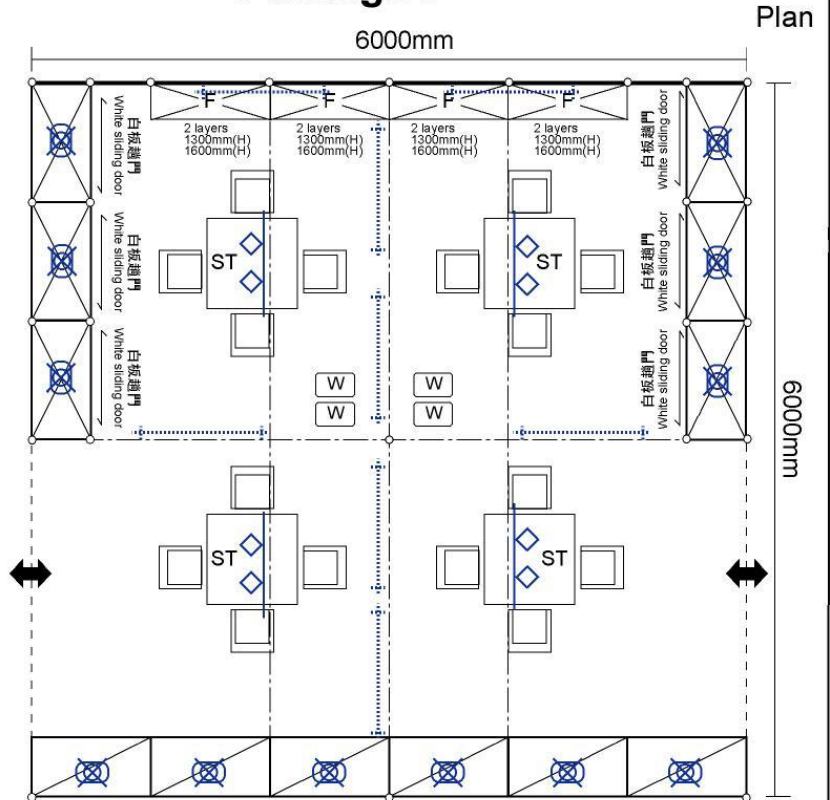

攤位組合的所有飾櫃可自由選擇高身陳列飾櫃或矮身陳列飾櫃  
 All showcase within the Package can interchange between Tall showcase or Counter showcase.

## HKIJMS 2014 FURNITURE

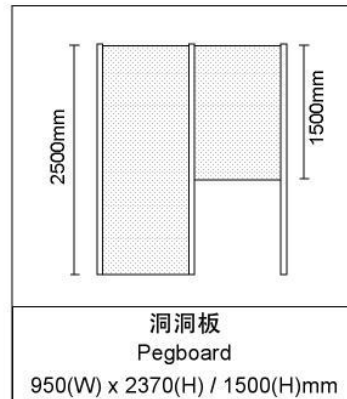
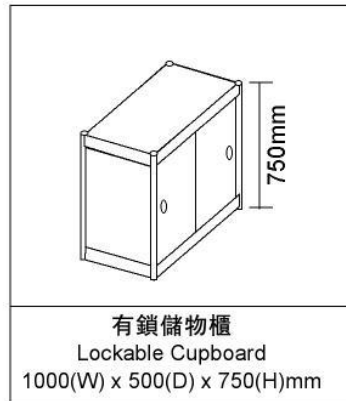
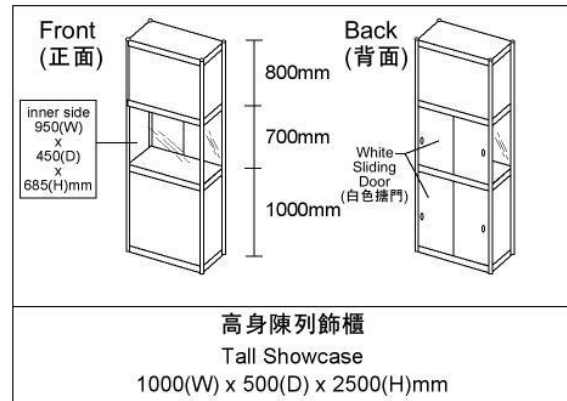
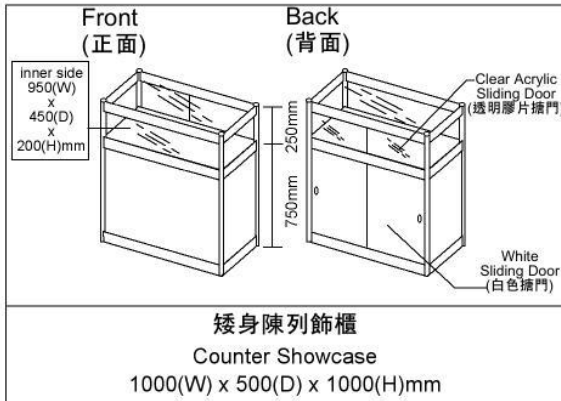

### **CONDITIONS OF ORDER FOR RENTAL FACILITIES (FURNITURE & ELECTRICITY)**

1. Location for installation of items in above order form must be clearly illustrated by exhibitors in sketch or drawing, e.g. booth layout plan or elevation.
2. All orders for services/ equipment rental should be submitted with full payment together with any damage/ security deposit if necessary. Orders without the required payment(s) will not be entertained.
3. All equipment provided by ORGANIZER shall only be utilized within the exhibition venue exclusively for the specified event(s).
4. Provisions of any services/ equipment by ORGANIZER and OFFICIAL AGENT/CONTRACTOR are subject to the availability of the required services/equipment at the time of ordering. Orders will be entertained on a "first come first served" basis. However, ORGANIZER reserves the right not to entertain any others received and in such cases, the users will be notified and cheque payment will be returned or refunded.
5. If by reason of labor difficulties or shortage of materials or any other causes beyond the control of ORGANIZER, which make ORGANIZER be unable to provide all or any of the services or equipment ordered during the whole or any part of the duration of the specified event, hirer's right will be limited to the refund of a corresponding proportion of the charges for those services or equipment.
6. Hirer shall be responsible for returning all rented equipment and related materials to ORGANIZER within one hour on the last open day following the close of the relevant event.
7. Hirer shall use the equipment in a careful and proper manner and in accordance with rules and regulations issued by ORGANIZER. Hirer is not allowed to make any alterations modifications, attachments and/or additions to the equipment rented.
8. All equipments not supplied by ORGANIZER (lighting fixtures included) are not allowed to be installed on shell booth structure provided by ORGANIZER or OFFICIAL AGENT/CONTRACTOR. No tapes, stickers, graphics, nails or any kind of fixtures are allowed to be affixed to the system panels, aluminum profiles, flooring and ceiling of the stand. Otherwise, the fixtures should be removed by the hirer immediately. The hirer is fully liable for any loss or damage to the equipment and structure and any loss incurred for any case of accidents howsoever arises and need to compensate for the damage incurred.
9. Hirers are responsible to check whether all their rental furniture and electrical fixtures are in CORRECT QUANTITIES AND GOOD CONDITIONS before the commencement of exhibition. Any incorrect quantities should be reported to the site office of OFFICIAL AGENT/CONTRACTOR before the opening of the fair. NO REFUND will be made for incorrect quantities reported after show opening.
10. Hirer shall be liable for any loss or damage to the equipment arising from the hirer's negligence, unintentional act, unauthorized maintenance or other cause within the reasonable control of hirer, its representative, employees, agents or invitees. In the event of any loss or damage to the equipment for which hirer is liable, the hirer shall reimburse ORGANIZER for all cost of making good or replacement.
11. Hirer shall be default hereunder if hirer fails to pay any charges when due or any other indebtedness or fails to return the equipment to ORGANIZER after use.
12. For exhibitors who will bring their own electrical items (lighting fixtures included) in the booth, they need to fill in the Form 2.6A for additional electricity. If exhibitors who do not declare before they install the extra electrical items and cause "short circuit", exhibitors should bear the responsibility and HKJMA will reserve the right for claim against any loss and damage.
13. At any time after the hirer's default, ORGANIZER and its agent/contractor may terminate the rental services, by notice to hirer and repossess the equipment. Hirer shall remain liable for all unpaid charges and ORGANIZER may apply and retain all or a portion of the hirer's security/damage deposit as may be necessary to compensate ORGANIZER and its agent/contractor for any unpaid charges or damages and expenses incurred on account of such default; or ORGANIZER may exercise any other rights occurring to a less or under any applicable law upon a default by lessee.

### **攤位設施之租用及電力接駁的一般守則**

1. 參展商如租用以上各申請表內之設施，須以草圖或繪圖適當顯示安放位置，例如提供攤位設計圖則或平視圖。
2. 所有租用服務或設施申請，必須連同全部費用一併交回，及在須要時加付保障/損壞保金，不連款項申請表，概不受理。
3. 主辦機構提供的所有設施，只能在展覽會場為該項活動專用。
4. 主辦機構/大會指定代理/承建商能否提供參展商所需的服務/設施，要視乎接到申請時有關服務/設施是否仍可供租用。申請表將以「先到先得」的方式處理，但主辦機構保留不接納申請的權利。
5. 如因不可抗力、勞工問題、物資短缺或其他非主辦機構所能控制的因素，致使主辦機構不能在指定活動進行期間，提供已租用的部分或全部服務或設施，承租人只能按比例取回已付出的服務或設施費用。
6. 承租人須負責在最後一天展覽活動結束後一小時內，將所有租用的設備及有關物料交回主辦機構。
7. 承租人必須謹慎而正確地使用有關設施，遵守主辦機構定下的條例和規則，不得擅自更改設施的用途和結構或增添附加裝置。
8. 非主辦機構供應的設施(包括照明裝置)均不得安裝或裝嵌在標準展台結構的物料上。圍板、地板、天花板上不得貼上任何膠紙或膠布，亦不得嵌釘、鑽孔，塗污或加裝任何裝置。一經發現，承租人必須要將其拆除。展覽展台及展場內裝置如有任何損毀，一概由承租人負責。大會承建商可向承租人追討其費用。
9. 承租人必須於展覽會開幕前驗收攤位內設施之數量及狀況，否則所有接收之設施均論為完整無缺。任何不正確的數量及損壞，應於展覽會開幕前當報大會指定承建商現場辦事處。主辦機構/大會指定承建商於展覽會開幕後均不會作出退款。
10. 因承租人的疏忽、非蓄意行為，未經許可的維修或在租用者、其代表、僱員、代理人或所邀請訪客可以控制的情況下對設施造成的損毀，承租人必須負責。主辦機構因此更換設施或作出賠償而涉及的所有費用，須由承租人繳付。
11. 承租人如未能如期繳款、償付其他欠款或於設施使用完畢後未能交回主辦機構，則作違約論。
12. 若承租人需要安裝自行攜帶之電器(包括照明裝置)，承租人必須填寫表格2.6A申報額外電力。若安裝自行攜帶之電器而未經申報，一旦引起電力短路問題，本會將作出追究。承租人亦需要負上因事件而引起之金錢損失。
13. 承租人違約，主辦機構可在發出通知後，終止提供的租賃服務，收回租出的設施，承租人仍須負責所有未付款項。主辦機構在需要時，有權申請扣除承租人所繳交的部分或全部保障 / 損壞賠償金，或根據法例行使其他索償權利。

## Form 2.5 Rental of Additional Furniture

Return to 交回: AKI Productions Ltd.

Tel 電話: +852 2697-1221 Fax 傳真: +852 2603-0814 Email 電郵: show@akipro.com.hk

Deadline : October 10, 2014

Optional for Standard  
Booth Exhibitors

No.	ITEM	Advanced Order (HK\$)	Standard Order (HK\$)	On-site Order (HK\$)	Qty.	Total Amount (HK\$)
1	Square table (760 x 760 x 730H mm)	280	325	365		
2	Rectangular table (1200 x 760 x 730H mm)	400	460	520		
3	Information counter (1000 x 500 x 750H mm)	330	380	430		
4	Black leather chair	90	105	120		
5	Folding chair	50	58	65		
6	Folding door	400	460	520		
7	Bar stool	200	230	260		
8	Bombo stool	350	405	455		
9	Lockable cupboard (1000 x 500 x 750H mm)	460	530	600		
10	Flat Shelf (1000 x 300 mm)	140	160	185		
11	Slope shelf (1000 x 300 mm)	140	160	185		
12	Glass shelf inside showcase (1000 x 500 mm)	200	230	260		
13	Tall showcase with 3 built-in halogen downlights (50W) (yellow light) (1000 x 500 x 2500H mm)	1,930	2,220	2,510		
14	Tall showcase with 1 built-in strong white light (70W) (1000 x 500 x 2500H mm)	2,030	2,335	2,640		
15	Tall showcase with 3 built-in LED downlights (5W) (white light) (1000 x 500 x 2500H mm)	2,230	2,565	2,900		
16	Built-in fluorescent tube inside tall showcase (white light)	385	440	500		
17	Built-in halogen downlight (50W) inside tall showcase (yellow light)	450	515	585		
18	Built-in LED downlight (5W) inside tall showcase (white light)	550	630	715		
19	Counter showcase with lockable cupboard (1 built-in fluorescent tube included) (1000 x 500 x 1000Hmm)	1,245	1,430	1,620		
20	Counter showcase with lockable cupboard (no light) (1000 x 500 x 1000Hmm)	900	1,035	1,170		
21	Built-in fluorescent tube inside counter showcase (white light)	385	440	500		
22	Mini-spotlight (50W) inside counter or tall showcase (yellow light)	450	515	585		
23	Display Cabinet (1000 x 500 x 1000H mm)	750	860	975		
24	Pegboard with 30 hooks (2500 x 1000 mm)	500	575	650		
25	Partition wall (1000 x 2500 mm)	265	305	345		
26	Partition wall (500 x 2500 mm)	190	220	250		
27	Ceiling beam per meter	60	70	80		
28	Waste basket	35	40	45		
<b>TOTAL</b>						

**Terms and Conditions:**

- All orders must be submitted with full payment. If order is accepted, all payment is non-refundable. Payment can be made by cheque or bank transfer.
- Orders deadline: Advance order price: On or before Oct. 10, 2014  
Standard order price: On or before Oct. 24, 2014  
On-site order price: On or after Oct. 25, 2014

AKI Productions Ltd. reserves the right to accept late order (after October 10, 2014).

**For payment method, please refer to P.38. 有關付款方法，詳情請參閱第38頁。**

Company Name 公司名稱: \_\_\_\_\_  
Booth Number 攤位號碼: \_\_\_\_\_ Contact Person 負責人: \_\_\_\_\_  
Tel 電話: \_\_\_\_\_ Fax 傳真: \_\_\_\_\_ Email 電郵: \_\_\_\_\_

**表格2.5 租用額外傢俬設施**

標準攤位之參展商  
 隨意交回

Return to 交回: AKI Productions Ltd.

Tel 電話: +852 2697-1221 Fax 傳真: +852 2603-0814 Email 電郵: show@akipro.com.hk

截止日期: 2014年10月10日

No.	物品	優惠租金 (HK\$)	標準租金 (HK\$)	現場租金 (HK\$)	數量	合計 (HK\$)
1	四方檯 (760 x 760 x 730H mm)	280	325	365		
2	長方檯(1200 x 760 x 730H mm)	400	460	520		
3	諮詢檯 (1000 x 500 x 750H mm)	330	380	430		
4	黑皮椅	90	105	120		
5	摺椅	50	58	65		
6	摺門	400	460	520		
7	吧椅	200	230	260		
8	油壓吧椅	350	405	455		
9	有鎖儲物櫃 (1000 x 500 x 750H mm)	460	530	600		
10	平放式陳列架(1000 x 300 mm)	140	160	185		
11	斜放式陳列架(1000 x 300 mm)	140	160	185		
12	飾櫃內置玻璃層板(1000 x 500 mm)	200	230	260		
13	高身陳列飾櫃連3盞內置石英燈 (50W) (黃光) (1000 x 500 x 2500H mm)	1,930	2,220	2,510		
14	高身陳列飾櫃連1盞內置白光燈 (70W) (1000 x 500 x 2500H mm)	2,030	2,335	2,640		
15	高身陳列飾櫃連3盞內置LED燈 (5W) (白光) (1000 x 500 x 2500H mm)	2,230	2,565	2,900		
16	高身陳列飾櫃內置光管 (白光)	385	440	500		
17	高身陳列飾櫃內置石英燈 (50W) (黃光)	450	515	585		
18	高身陳列飾櫃內置LED燈 (5W) (白光)	550	630	715		
19	矮身陳列飾櫃連有鎖儲物櫃 (包括1支內置光管) (1000 x 500 x 1000Hmm)	1,245	1,430	1,620		
20	矮身陳列飾櫃連有鎖儲物櫃 (不包括照明裝置) (1000 x 500 x 1000Hmm)	900	1,035	1,170		
21	矮身陳列飾櫃內置光管 (白光)	385	440	500		
22	飾櫃內置射燈 (50W) (適用於矮身或高身陳列飾櫃) (黃光)	450	515	585		
23	櫃檯 (1000 x 500 x 1000H mm)	750	860	975		
24	洞洞板連30隻短勾 (2500 x 1000 mm)	500	575	650		
25	圍板 (1000 x 2500 mm)	265	305	345		
26	圍板 (500 x 2500 mm)	190	220	250		
27	天花鋁架 (每米)	60	70	80		
28	廢物箱	35	40	45		
<b>合計</b>						

註明:

- 所有額外設施申請必須連同所需款項交回, 否則恕不受理。若申請被接受, 所有已繳交之費用將不予退回。所需款項可以支票或銀行轉帳支付。
- 租用物品截止日期: 優惠租金: 2014年10月10日或之前  
 標準租金: 2014年10月24日或之前  
 現場租金: 2014年10月25日或之後

若於截止日期後遞交此申請表 (2014年10月10日以後), AKI Productions Ltd. 保留接受申請之權利。

**For payment method, please refer to P.38. 有關付款方法, 詳情請參閱第38頁。**

Company Name 公司名稱: \_\_\_\_\_

Booth Number 攤位號碼: \_\_\_\_\_

Contact Person 負責人: \_\_\_\_\_

Tel 電話: \_\_\_\_\_

Fax 傳真: \_\_\_\_\_

Email 電郵: \_\_\_\_\_

Company Chop & Authorized Signature 公司蓋章及簽署

Date 日期

## Form 2.6A Rental of Additional Lights and Electricity

Return to 交回: AKI Productions Ltd.

Tel 電話: +852 2697-1221 Fax 傳真: +852 2603-0814 Email 電郵: show@akipro.com.hk

**Deadline : October 10, 2014**

Optional for Standard  
Booth Exhibitors

No.	ITEM	Advanced Order (HK\$)	Standard Order (HK\$)	On-site Order (HK\$)	Qty.	Total Amount (HK\$)
1	Energy saving bulb spotlight (23W) (yellow light)	325	375	425		
2	Energy saving bulb longarm spotlight (23W) (yellow light)	345	395	450		
3	Floodlight (300W) (yellow light)	780	895	1,015		
4	Floodlight (500W) (yellow light)	910	1,050	1,185		
5	1m light track with 1 halogen track light (50W) (yellow light)	470	540	610		
6	1m light track with 1 LED track light (5W) (white light)	690	795	900		
7	1m light track (light is NOT included) (Used ONLY for track light supplied by official contractor. Light connection fee will be charged for exhibitors' own tracklight)	300	345	390		
8	Halogen track light (50W) (yellow light) (no light track)	280	320	365		
9	LED track light (5W) (white light) (no light track)	500	575	650		
10	Fluorescent tube (White Light) (1200mm L)	325	375	425		
11	Strong White Light (70W)	990	1,140	1,290		
12	Strong White Light (250W)	1,400	1,610	1,820		
13	Power socket (500W) (220V) (use for lighting connection is prohibited)	400	460	520		
14	24 hours power socket (500W) (220V)	790	910	1,030		
15	Light connection of EACH individual lighting fixture with electricity. (Lighting installation is NOT included, NO socket will be provided)					
	100W	230	265	300		
	200W	310	360	405		
	300W	390	450	505		
	400W	470	540	610		
	500W	550	630	715		
16	Installation for EACH individual lighting fixture (with built-in transformer)	130	150	170		
17	Socket 500W (220V) for lighting fixtures	1,210	1,390	1,575		
18	Socket 1000W (220V) for lighting fixtures	2,420	2,785	3,150		
<b>TOTAL</b>						

**Terms and Conditions:**

- All orders must be submitted with full payment. If order is accepted, all payment is non-refundable. Payment can be made by cheque or bank transfer.
- Orders deadline: Advance order price: On or before Oct. 10, 2014  
 Standard order price: On or before Oct. 24, 2014  
 On-site order price: On or after Oct. 25, 2014

AKI Productions Ltd. reserves the right to accept late order (after October 10, 2014).

**For payment method, please refer to P.38. 有關付款方法，詳情請參閱第38頁。**

Company Name 公司名稱: \_\_\_\_\_  
 Booth Number 攤位號碼: \_\_\_\_\_ Contact Person 負責人: \_\_\_\_\_  
 Tel 電話: \_\_\_\_\_ Fax 傳真: \_\_\_\_\_ Email 電郵: \_\_\_\_\_

Company Chop & Authorized Signature 公司蓋章及簽署

Date 日期

**表格2.6A 租用額外電燈及電力設施**

Return to 交回: AKI Productions Ltd.

Tel 電話: +852 2697-1221 Fax 傳真: +852 2603-0814 Email 電郵: show@akipro.com.hk

截止日期: 2014年10月10日

No.	物品	優惠 租金 (HK\$)	標準 租金 (HK\$)	現場 租金 (HK\$)	數量	合計 (HK\$)
1	射燈節能燈膽 (23W) (黃光)	325	375	425		
2	長臂射燈節能燈膽 (23W) (黃光)	345	395	450		
3	泛光燈 (300W) (黃光)	780	895	1,015		
4	泛光燈 (500W) (黃光)	910	1,050	1,185		
5	1米路軌連1盞路軌石英燈 (50W) (黃光)	470	540	610		
6	1米路軌連1盞路軌LED燈 (5W) (白光)	690	795	900		
7	1米路軌 (不包括任何路軌燈) (只可用於大會承建商所供應之路軌燈。若參展商於此路軌上使用自備之路軌射燈, 須繳付照明裝置之電線接駁及供電費用。)	300	345	390		
8	路軌石英燈 (50W) (黃光) (不包括路軌)	280	320	365		
9	路軌LED燈 (5W) (白光) (不包括路軌)	500	575	650		
10	光管 (白光) (1200mmL)	325	375	425		
11	白光燈 (70W)	990	1,140	1,290		
12	白光燈 (250W)	1,400	1,610	1,820		
13	電源插座 (500W) (220V) (不可用於接駁照明裝置)	400	460	520		
14	24小時供電插座 (500W) (220V)	790	910	1,030		
15	每支照明裝置之電線接駁及供電(不包括安裝照明裝置的費用及電源插座)					
	100W	230	265	300		
	200W	310	360	405		
	300W	390	450	505		
	400W	470	540	610		
	500W	550	630	715		
16	安裝每支照明裝置 (內置火牛)	130	150	170		
17	燈具插頭 (500W) (220V)	1,210	1,390	1,575		
18	燈具插頭 (1000W) (220V)	2,420	2,785	3,150		
<b>合計</b>						

註明:

- 所有額外設施申請必須連同所需款項交回, 否則恕不受理。若申請被接受, 所有已繳交之費用將不予退回。所需款項可以支票或銀行轉帳支付。
- 租用物品截止日期: 優惠租金: 2014年10月10日或之前  
 標準租金: 2014年10月24日或之前  
 現場租金: 2014年10月25日或之後

若於截止日期後遞交此申請表 (2014年10月10日以後), AKI Productions Ltd. 保留接受申請之權利。

**For payment method, please refer to P.38. 有關付款方法, 詳情請參閱第38頁。**

Company Name 公司名稱: \_\_\_\_\_

Booth Number 攤位號碼: \_\_\_\_\_ Contact Person 負責人: \_\_\_\_\_

Tel 電話: \_\_\_\_\_ Fax 傳真: \_\_\_\_\_ Email 電郵: \_\_\_\_\_

Company Chop & Authorized Signature 公司蓋章及簽署

Date 日期



**Form 2.6B Rental of Additional Electricity**  
**表格2.6B 租用額外電力設施**

Return to 交回: AKI Productions Ltd.

Tel 電話: +852 2697-1221 Fax 傳真: +852 2603-0814 Email 電郵: show@akipro.com.hk

**Deadline : October 10, 2014 | 截止日期 : 2014年10月10日**

No.	Item 物品	Advanced Order 優惠租金 (HK\$)	Standard Order 標準租金 (HK\$)	On-site Order 現場租金 (HK\$)	Quantity 數量	Total amount 合計 (HK\$)
1	15 Amp single phase (220V) for lighting connections AND power supply to electrical appliances 供電燈接線及小型電器用之15安培單相配電總制 (220伏特)	5,600	6,440	7,280		
2	30 Amp single phase (220V) for lighting connections AND power supply to electrical appliances 供電燈接線及小型電器用之30安培單相配電總制 (220伏特)	10,600	12,190	13,780		
3	15 Amp three phase (380V) for lighting connections AND power supply to electrical appliances 供電燈接線及小型電器用之15安培三相配電總制 (380伏特)	15,500	17,830	20,150		
4	30 Amp three phase (380V) for lighting connections AND power supply to electrical appliances 供電燈接線及小型電器用之30安培三相配電總制 (380伏特)	29,500	33,930	38,350		
5	24 hours power consumption (500W) 24小時電源提供 (500W) *Installation is not included. 不包括安裝	650	750	845		
<b>TOTAL 合計</b>						

Terms and Conditions 註明 :

- All orders must be submitted with full payment. If order is accepted, all payment is non-refundable. Payment can be made by cheque or bank transfer. 所有額外設施申請必須連同所需款項交回, 否則恕不受理。若申請被接受, 所有已繳交之費用將不予退回。所需款項可以支票或銀行轉帳支付。
- Orders deadline: Advance order price: On or before Oct. 10, 2014 優惠租金: 2014年10月10日或之前  
 租用物品截止日期: Standard order price: On or before Oct. 24, 2014 標準租金: 2014年10月24日或之前  
 On-site order price: On or after Oct. 25, 2014 現場租金: 2014年10月25日或之後

AKI Productions Ltd. reserves the right to accept late order (after October 10, 2014).

若於截止日期後遞交此申請表 (2014年10月10日以後), AKI Productions Ltd. 保留接受申請之權利。

- For items 1-5, exhibitors must have their own Hong Kong licensed electrician. The official contractor will not provide any installation and connection service for these items. 選用項目1-5的電力供應之參展商必須自行聘請持牌電工。大會承建商將不會提供安裝及接駁服務予選用上電力供應之參展商。
- All design should be submitted together with electrical and circuit plan. 所有設計必須連同電路圖一併交回。
- All electrical performance must be accompanied with the rules and regulations of HKCEC. 所有電力接駁及設計必須符合香港會議展覽中心有關規定。
- Raw Space exhibitors have been supplied with 1000W electricity to each 9 m<sup>2</sup> booth. If they need any additional electricity supply, please contact Official Contractor directly.  
每九平方米之空地參展商已獲分配1000W電力。若空地參展商需要額外電力, 可直接與主辦機構指定之承建商聯絡。

**For payment method, please refer to P.38. 有關付款方法, 詳情請參閱第38頁。**

Company Name 公司名稱: \_\_\_\_\_  
 Booth Number 攤位號碼: \_\_\_\_\_ Contact Person 負責人: \_\_\_\_\_  
 Tel 電話: \_\_\_\_\_ Fax 傳真: \_\_\_\_\_ Email 電郵: \_\_\_\_\_

Company Chop & Authorized Signature 公司蓋章及簽署

Date 日期



**TELEPHONE, FACSIMILE, CABLING AND BROADBAND INTERNET SERVICE CHARGES - ORDER FORM**  
(Rates Effective July 2014 - June 2015)

Event Name: \_\_\_\_\_  
Move in: \_\_\_\_\_ Open Period: \_\_\_\_\_ Move Out: \_\_\_\_\_  
Venue/Booth No: \_\_\_\_\_  
Deadline: \_\_\_\_\_ (21 days before 1st day of Licensed Period)

(For office use)
EVENT ID: _____
LOG NO: _____

1. Telephone	Quantity	HK\$ per set per Event	Deposit HK\$ Per Line	Total HK\$
a Telephone (Local calls only) through the HKCEC's PABX system		930	--	
b Telephone (Local and IDD calls) through the HKCEC's PABX system		1,168	2,500	

2. Facsimile	Quantity	HK\$ per set per Event	Deposit HK\$ Per Line	Total HK\$
a Local Facsimile Transmission line through the HKCEC's PABX system (Facsimile machine excluded)		930	--	
b IDD Facsimile Transmission line through the HKCEC's PABX system (Facsimile machine excluded)		1,168	2,500	

3. Cabling	Quantity	HK\$ per set per Event	Deposit HK\$ Per Line	Total HK\$
a Direct Dial-up Credit Authorisation line (Card machine and bank account excluded)		1,168	--	
b EPS line (Card machine and EPS account excluded)		1,168	--	

4. Broadband	Period		Quantity	HK\$ per 4-consecutive days of use following day of installation	HK\$ Per Additional Day	Deposit HK\$ Per Line	Total HK\$
	From	To					
a 2M bps				1,871	465	4,000	

Please indicate your telecom needs for our easy reference:

T: Telephone  
F: Fax  
D: Data line  
I: ISDN line

Booth No : \_\_\_\_\_

Back  
Left  Right  
Front

Total without adjustment	_____
Late order surcharge 15%	_____
Site order surcharge 30%	_____
Total Amount	_____
Cancellation charge	_____

**REMARKS:**

- Call charges are excluded for telephones with IDD service, overseas facsimile transactions and data communication calls. All IDD call charges plus a handling fee (minimum \$20 per call) will be deducted from the deposit paid, or any excess will be settled by User before the close of the event.
- A charge of HK\$ 600 per set will apply for lost and / or damaged telephone sets.
- A charge of HK\$4,000 per set will apply for lost and / or damaged Interface Modem and / or power adaptor.
- One 2M broadband line supports 1 computer only.
- The minimum lead time to order additional broadband lines is 3 weeks.
- Licensee or exhibitors are strictly prohibited from connecting the rented broadband lines to any device such as Wireless Access Points or computers to provide any form of ad-hoc wireless networking services which may adversely impact in any way HKCEC's existing Wireless System.
- Please see enclosed for General Notes and Conditions.
- Orders will not be processed until full payment is made.

<p><b>CREDIT CARD INFORMATION:</b></p> <p><input type="checkbox"/> AMEX    <input type="checkbox"/> VISA    <input type="checkbox"/> MASTER    <input type="checkbox"/> DINERS</p> <p>Card Number: _____</p> <p>Cardholder Name: _____</p> <p>Expiry Date: _____ Signature: _____</p>	<p><b>AUTHORIZATION FROM USER:</b></p> <p>Company Name: _____</p> <p>Company Address: _____</p> <p>Tel No.: _____ Name (in caps): _____</p> <p>Fax No.: _____ Signature: _____</p> <p>Date: _____</p>
---	---

PLEASE RETURN THIS FORM TO:

Hong Kong Convention & Exhibition Centre (Management) Ltd.  
Event Planning & Co-ordination Department  
1 Expo Drive, Wanchai, Hong Kong, China  
Tel: (852) 2582 8888 Fax: (852) 2582 7106